

# LF

## 260 Specification sheet

FA 4X2 Rigid, 12t Chassis/Body



*\*Some optional equipment maybe shown in this brochure.*

### ENGINE

LF 260 PX-7 (189 kW / 257 hp)

### GVM

12,000 kg

Max. front 4,480 kg

Max. rear 8,480 kg

### GCM

16,000 kg

**THE DAF LF**  
PURE EXCELLENCE

**DAF**

# LF 260

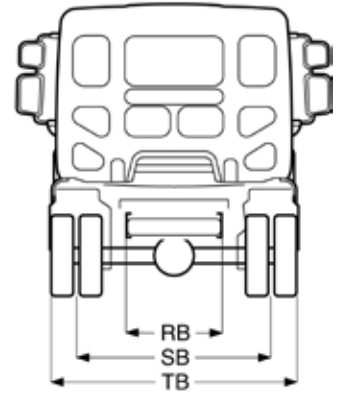
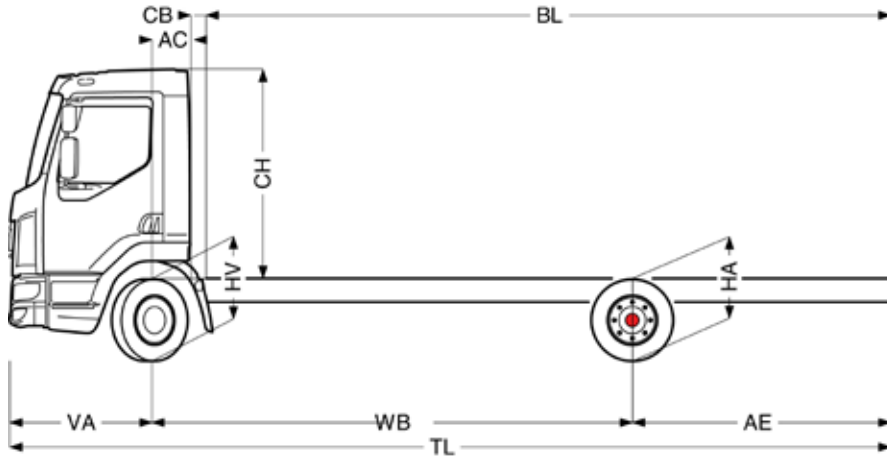

	Wheelbase – AE		Unladen Weight <sup>1)</sup>			Variable Dimensions								
	WB	AE	Front	Rear	Total	AC	CB	CH <sup>2)</sup>	BL	TL	HA <sup>3)</sup>	HA <sup>4)</sup>	TK <sup>5)</sup>	TW <sup>6)</sup>
<b>SLEEPER</b>	4.65	2.65	2990	1330	4320	0.73	0.22	1.87	6.35	8.57	0.81	0.79	14.45	15.85
<b>SLEEPER</b>	5.70	2.30	3020	1340	4360	0.73	0.22	1.87	7.05	9.27	0.81	0.79	17.04	18.46
<b>SLEEPER</b>	6.40	2.70	3060	1370	4430	0.73	0.22	1.87	8.15	10.37	0.81	0.79	18.77	20.21
<b>OTHER DIMENSIONS</b>			<b>VA: 1.275</b>		<b>HV<sup>7)</sup>: 0.81</b>	<b>HV<sup>8)</sup>: 0.72</b>	<b>RB: 0.86</b>	<b>SB: 1.736</b>	<b>TB<sup>9)</sup>: 2.274</b>					

1. Chassis and cab weight calculated with: Standard specification items only, less fuel, AdBlue and driver, tolerance  $\pm 3\%$ . Changing of the specification can have major impact on vehicle weight.
2. Cab height is measured from frame member to closed cab roof hatch.
3. Unladen height at centre of driven axle(s).
4. Laden height at centre of driven axle(s).

5. TK is turning circle between curbs.
6. TW is turning circle between walls.
7. Unladen height at centre of front axle(s).
8. Laden height at centre of front axle(s).
9. TB is overall width at rear. (At centre of front axle 250).

Note: All dimensions are in metres (m) and weights in kilograms (kg).

## CAB EXTERIOR

Sleeper Cab, width 2130 mm; mechanical cab suspension; Steel bumper; Tinted glass and electric windows; Main mirrors and wide angle mirrors electrically adjustable and heated; Front view mirror. LED Daytime running lights; Fog lights and cornering lights.

### Optional

- Day cab
- Extended Day cab

## AERODYNAMICS

- Side collars
- Adjustable roof spoiler

## COLOURS

Cab colour M8870 White; Head lamp panel and bumper colour M8870 White; Chassis colour black.

## CAB INTERIOR

Driver seat: air suspended; Co-driver seat: fixed velour; Pneumatically adjustable steering column; lower bunk; Air conditioning.

## COMMUNICATION AND DRIVING MANAGEMENT

AM/FM Premium Audio System with CD player; FMS connector prepared.

### Optional

- Integrated TruckPhone

## SAFETY AND SECURITY

Adaptive Cruise Control (ACC); Forward Collision Warning (FCW); Advanced Emergency Braking System (AEBS-3); Lane Departure Warning System (LDWS); Vehicle Stability Control (VSC); Protective cab suspension and construction; Air bag (driver) and 2 seat belt tensioners; Reverse warning; Basic engine immobiliser system.

## SUSPENSION AND AXLES

Front: 4.50t, parabolic, F48; Rear: 8.50t, air suspension, SR8.22.

## WHEELS AND TYRES

Front axle 1: 245/70R17.5; Rear axle 1: 245/70R17.5; Wheel protection rings silver/grey.

## DRIVELINE

Engine PX-7; 6 cylinder diesel engine, 6.7 litres; Output 194 kW (189 kW / 257 hp) at 2,300 rpm; Maximum torque 990 Nm at 1,000-1,700 rpm; Exhaust emission Euro 6; Engine idle shut down after 5 minutes; PowerLine gearbox; 8 speeds; Gearbox ratio 4.89 - 0.64; Rear axle ratio 3.73.

## BRAKE SYSTEM

Exhaust Brake; Park brake control with test position; Ventilated disc brakes front and rear; Dual circuit air system with electronic control (EBS).

## CHASSIS

Wheelbase 4.65 m, rear overhang 2.65 m; Side member height 210 mm; EAS unit right side; Fuel tank 185 l; Spray suppression; Front underrun protection (FUP); AdBlue tank 50 l; LED rear lights.

## BODIES AND PREPARATIONS FOR BODYING

BodyBuilder Module (BBM); Application connector to chassis; Standard body attachment hole pattern.

## POWER TAKE-OFF (PTO)

Various PTO types and positions.

## ELECTRICAL POWER SUPPLY

Alternator 80 A; Batteries 2x 175 Ah.

## GVM AND GCM

Chassis weight related technical GVM max 16,000 kg.

## APPLICATION CONDITIONS

Moisture separator, unheated; Air intake, high.

## VEHICLE DELIVERY

Standard toolkit.

## VEHICLE WARRANTY

Three (3) years or 200,000 km complete vehicle warranty, whichever comes first.



**DAY CAB**



**SLEEPER CAB**



**EXTENDED CAB**

DAF Trucks Australia  
66 Canterbury Road Bayswater VIC 3153  
Phone (03) 9721 1600