

CF

370 | 410 | 450

Specification sheet

FAD 8X4 Rigid



ENGINES

CF 370 MX-11 (270 kW / 367 hp)

CF 410 MX-11 (300 kW / 408 hp)

CF 450 MX-11 (330 kW / 449 hp)

GVM

32,300 kg

Max. front 14,200 kg

Max. rear 18,100 kg

GCM

60,000 kg

THE DAF CF
PURE EXCELLENCE

DAF

CF 370 | 410 | 450

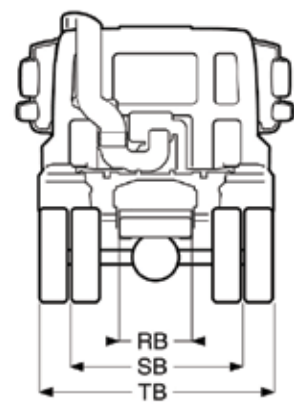
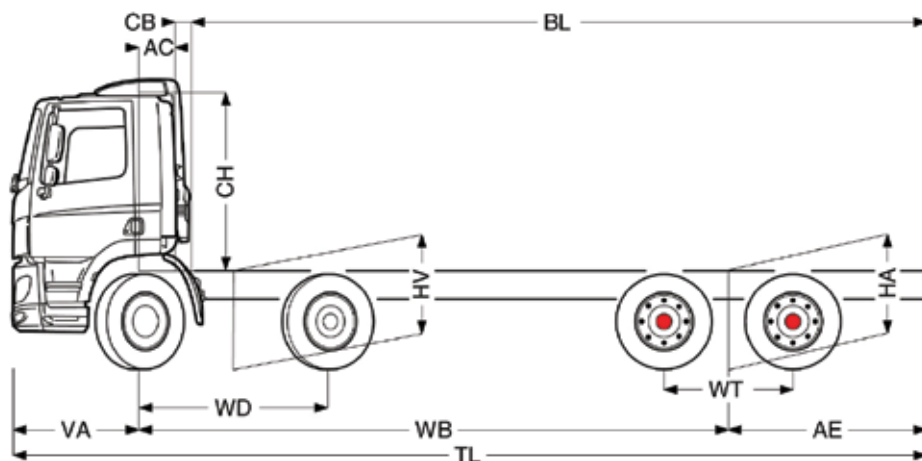

	Wheelbase – AE		Unladen Weight ¹⁾			Variable Dimensions									
	WB	AE	Front	Rear	Total	AC	CB ²⁾	CH ³⁾	BL	TL	HA ⁴⁾	HA ⁵⁾	TK ⁶⁾	TW ⁷⁾	
DAY CAB	6.00	2.25	6100	3020	9120	0.39	0.22	1.94	7.64	9.62	1.05	1.07	21.15	22.39	
	6.40	3.70	6050	3275	9325	0.39	0.22	1.94	9.49	11.47	1.05	1.07	22.70	23.95	
SLEEPER CAB	6.00	2.25	6250	3020	9270	0.82	0.22	1.94	7.21	9.62	1.05	1.07	21.15	22.39	
	6.40	3.70	6140	3275	9415	0.82	0.22	1.94	9.06	11.47	1.05	1.07	22.70	23.95	
SPACE CAB	6.00	2.25	6350	3020	9370	0.82	0.22	2.62	7.21	9.62	1.05	1.07	21.15	22.39	
	6.40	3.70	6250	3275	9525	0.82	0.22	2.62	9.06	11.47	1.05	1.07	22.70	23.95	

OTHER DIMENSIONS	VA: 1.37	WD: 2.00	WT: 1.40	HV⁸⁾: 1.08	HV⁹⁾: 1.02	RB: 0.79	SB: 1.82	TB¹⁰⁾: 2.48
-------------------------	-----------------	-----------------	-----------------	------------------------------	------------------------------	-----------------	-----------------	-------------------------------

1. Chassis and cab weight calculated with: Standard specification items only, less fuel, AdBlue and driver, tolerance $\pm 3\%$. Changing of the specification can have a major impact on vehicle weight.
2. CB is based on standard air intake and/or exhaust.
3. Cab height is measured from frame member to closed cab roof hatch. With air intake on cab roof add 0.21 m.
4. Unladen height at centre of driven axle(s).

5. Laden height at centre of driven axle(s).
6. TK = turning circle between kerbs.
7. TW = turning circle between walls.
8. Unladen height at centre of front axle(s).
9. Laden height at centre of front axle(s).
10. TB is overall width at rear.

Note: All dimensions are in metres (m) and weights in kilograms (kg).

CAB EXTERIOR

Day Cab with galvanised steel bumper, tinted glass and electric window openers; Cab width 2300 mm; External sun visor green translucent; LED head lights; Fog lights and cornering lights; Main mirrors and wide angle mirrors electrically heated and adjustable. Air horns.

Optional

- Sleeper Cab
- Space Cab

AERODYNAMICS

Optional

- Adjustable roof deflector
- Side collars

COLOURS

Cab colour M8870 White; Head lamp panel and bumper colour M8870 White; Chassis colour black.

Optional

- Other cab colours available

CAB INTERIOR

Cab interior trim colour Dark Sand; Cab interior decoration Black Rock; Driver seat Luxury Air; Co-driver seat Basic; Automatic Temperature Control; Roof hatch aluminium, manual control; Pollen filter.

Optional

- Leather steering wheel
- Exclusive cab interior trim colour
- Driver Seat: Xtra Leather Air (Exclusive interior only)
- Passenger Seat: Xtra Leather Air (Exclusive interior only)
- Third Seat (Day Cab only)

COMMUNICATION AND DRIVING MANAGEMENT

AM/FM/DAB Premium Multimedia System with Bluetooth® phone and music streaming capability, navigation and PACCAR Connect telematics functionality, 2 x GSM antennas, 1 x GPS antenna, 1 x DAB radio antenna.

SAFETY AND SECURITY

Adaptive Cruise Control (ACC); Forward Collision Warning (FCW); Advanced Emergency Braking System (AEBS-3); Lane Departure Warning System (LDWS); Vehicle Stability Control (VSC); Protective cab suspension and construction; Air bag (driver) and 2 seat belt tensioners; Reverse warning; Basic engine immobiliser system.

SUSPENSION AND AXLES

Front: 2x 7,100 kg, parabolic leaf springs.

Rear: 2x 9,050 kg, air suspension; SR1360T; Axle load monitoring.

WHEELS AND TYRES

Front axle 1: 295/80R22.5; Front axle 2: 295/80R22.5;

Rear axle 1: 11R22.5; Rear axle 2: 11R22.5; Alcoa Brushed alloy wheels.

Optional

- Alcoa Dura-Bright alloy wheels

DRIVELINE

Engine MX-11, multi torque 6 cylinder diesel engine, 10.8 litres. Output 450 hp at 1,600 rpm, maximum torque 2,300 Nm at 900-1,125 rpm, Exhaust emission Euro 6, 5 minute engine idle shut down, ZF TraXon Automated gearbox, 12 speeds, Gearbox ratio 12.92-0.77, rear axle ratio 3.40, ASR.

Optional

- Engine; 370 hp / 1,900 Nm torque
- Engine; 410 hp / 2,100 Nm torque

BRAKE SYSTEM

MX Engine Brake; Park brake control with test position; Ventilated disc brakes front and rear. Dual circuit air system with electronic control (EBS). Twin cylinder air compressor with heated dryer and economy mode.

CHASSIS

Wheelbase 6.40 m / rear overhang 3.70 m; Side member height 310 mm; Exhaust pipe horizontal, low; Aluminium fuel tank 430 l, height 620 mm; LED rear light unit; Spray suppression; Front Underrun Protection System (FUPS); AdBlue tank 45 litres on left-hand chassis.

POWER TAKE-OFF (PTO)

Various PTO types and positions.

ELECTRICAL POWER SUPPLY

Alternator 80 A; Batteries 2x 175 Ah.

GVM AND GCM

Chassis weight related technical GVM max 32,300 kg; Driveline related max GCM 60,000 kg.

APPLICATION CONDITIONS

Cyclonic air intake behind the cab.

VEHICLE WARRANTY

3 year / 750,000km warranty.



DAY CAB

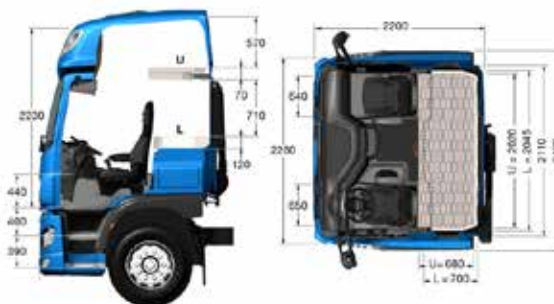

SPACE CAB

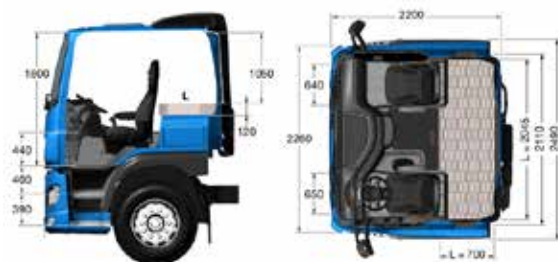

SLEEPER CAB

DAF Trucks Australia
66 Canterbury Road Bayswater VIC 3153
Phone (03) 9721 1600