

# FAT CF85 Hub reduction

## 6x4 Rigid

### Engines

CF85.360; 265 kW  
 CF85.410; 300 kW  
 CF85.460; 340 kW

### GVM<sup>1)</sup>

24600 kg  
 Max. front<sup>3)</sup>: 6500 kg  
 Max. rear: 18100 kg

### GCM<sup>2)</sup>

Application dependent



Wheelbase - AE		Unladen weight <sup>4)</sup>			Gross Carrying Capacity			Variable dimensions										
	WB	AE <sup>5)</sup>	Front	Rear	Total	Front	Rear	Total	AC	CB <sup>6)</sup>	CH <sup>7)</sup>	BL <sup>8)</sup>	BL <sup>8)</sup>	TL	HA <sup>9)</sup>	HA <sup>10)</sup>	TK <sup>11)</sup>	TW <sup>12)</sup>
Day	4.05	2.65	4720	3290	8010	1280	13210	14490	0.39	0.16	1.91	5.90	5.90	8.08	1.14	1.09	13.97	15.43
	4.55	2.75	4770	3340	8110	1230	13160	14390	0.39	0.16	1.96	6.70	6.70	8.68	1.01	0.99	15.26	16.75
	6.00	3.25	4900	3620	8520	1100	12880	13980	0.39	0.16	1.96	9.00	9.00	10.63	1.01	0.99	19.04	20.58
Sleeper	4.05	2.65	4815	3290	8105	1185	13210	14395	0.82	0.15	1.96	5.30	5.50	7.43	1.01	0.99	13.96	15.43
	4.55	2.75	4865	3340	8205	1135	13160	14295	0.82	0.15	1.96	6.20	6.30	8.68	1.01	0.99	15.26	16.75
	6.00	3.25	4995	3620	8615	1005	12880	13885	0.82	0.15	1.96	8.60	8.60	10.63	1.01	0.99	19.04	20.58

Other dimensions VA: 1.38 WT: 1.40 HV<sup>13)</sup>: 1.09 HV<sup>14)</sup>: 1.07 RB: 0.79 SB: 1.82 TB: 2.44

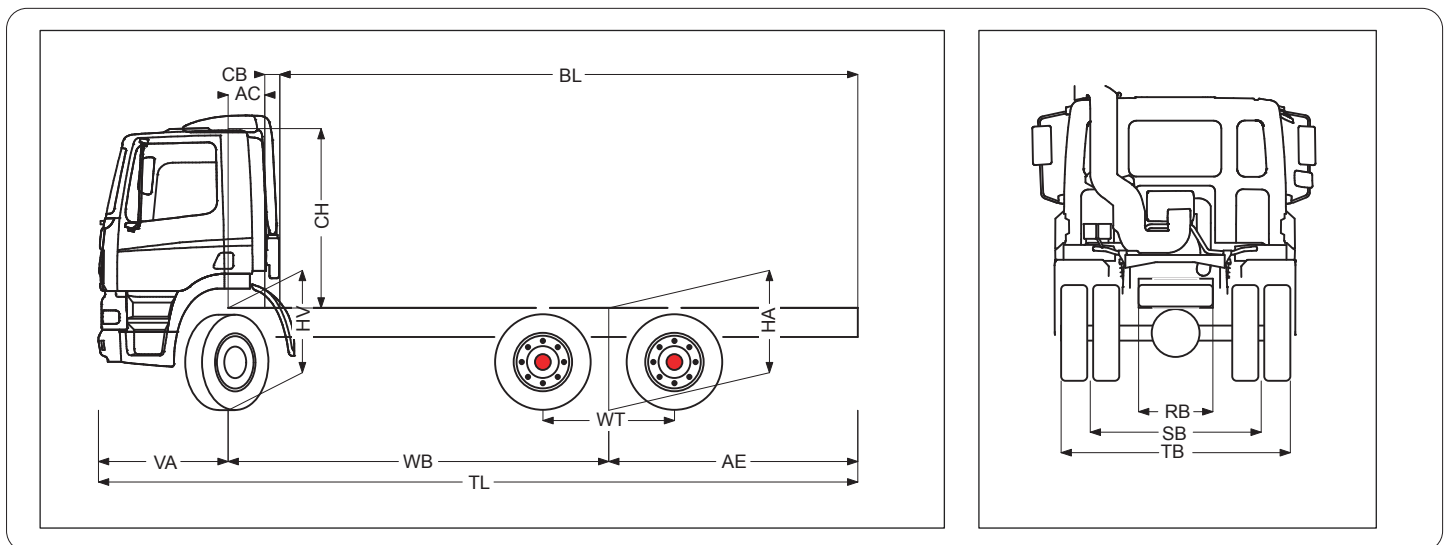

- 1) GVM in conformity with registration documents.
- 2) GCM in conformity with registration documents.
- 3) Axle load with standard tyre size.
- 4) Chassis and Cab Weight calculated with: Standard specification items and empty fuel tank. With Sleeper Cab; + 105 kg at front; Roof kit with extenders +73kg.
- 5) Other AE dimensions may be available for shown WB. Modify rear overhang to calculated body length.
- 6) CB is based on standard air intake and/or exhaust.
- 7) Cab height is measured from frame member to closed cab roof hatch. With air intake on cab roof: +0.14m

- 8) Calculate customer specific body length with TOPEC.
- 9) Unladen height at centre of driven axle(s).
- 10) Laden height at centre of driven axle(s).
- 11) TK = turning circle between kerbs.
- 12) TW = turning circle between walls.
- 13) Unladen height at centre of front axle(s).
- 14) Laden height at centre of front axle(s).

# FAT CF85 Hub reduction

## ENGINE

PACCAR	6 cylinder, turbo intercooled
Piston displacement	12.9 litres
Compression ratio	16.4 to 1
Fuel injection	Electronically controlled
Type	MX 300
Max output	300kW / 410hp at 1500-1900rpm
Max torque	2000Nm at 1000-1410rpm
Options:	
- Type	MX 265
Max output	265kW / 360hp at 1500-1900rpm
Max torque	1775Nm at 1000-1410rpm
- Type	MX 340
Max output	340kW / 462hp at 1500-1900rpm
Max torque	2300Nm at 1000-1410rpm

## CHASSIS

Completely flat topped chassis frame. Riveted and bolted construction of channel-section main frame members and cross members; 1 x 430 and 1 x 340 litre aluminium fuel tanks; Fuel tank height – 505 mm; 1x45 litre Adblue tank; Horizontal box type silencer at RHS with vertical pipe; Spray suppression behind steer tyre; Front underrun protection system (FUPS) on 152N front axle only; Dimensions main frame members: 310 x 75 x 7 mm with inner reinforcement (position and length depending on WB/AE); 4.05m wheelbase.

### Options:

- Wheelbase – 4.55m, 5.00m - 1 x 430 litre aluminium fuel tank
- Spare wheel carrier with spare wheel (only with 4.55m or 5.00m wheelbase and single fuel tank)

## GEARBOX

ZF AS Tronic - 12-speed overdrive automated gearboxes with oil cooler.

### Options:

- ZF Synchronised Manual – 16-speed overdrive manual gearbox with oil cooler

	MX 265	MX 300	MX340
12AS1930-12.33/0.78	X	-	-
12AS2130-12.33/0.78	-	X	-
12AS2330-12.33/0.78	-	-	X
16S2520-13.80/0.84	-	X	X

## CLUTCH

AS Tronic: Single type, pushed operation, asbestos free, dry plate, electronically operated, self adjusting servo.

Diameter: 430mm with torsional damper

ZF Synchronised Manual: Single type, pulled operation, asbestos free, dry plate, hydraulically operated and pneumatically assisted. Self adjusting.

Diameter: 430 mm

## FRONT AXLE

Type: 152N

Max. design load: 7500 kg

I-section axle. Stub axles with needle bearings.

### Options:

- 156N / 7500 kg straight axle

## REAR AXLE

Type: DAF HR 1355T

Max. design load: 26000 kg.

Double drive tandem axle with hub reduction and lockable inter axle and cross axle differentials. Crown wheel and pinion with spiral bevel primary reduction and straight spur hub reduction. (only with DAF suspension).

Ratios: 4.05

## FRONT SUSPENSION

Parabolic type leaf springs with shackled ends at rear – maintenance free; Shock absorbers and stabiliser bar.

Spring dimensions: 1x1800x80x31 + 1x1800x80x32 mm (7500 kg)

## REAR SUSPENSION

DAF trapezium leaf suspension. Spring travel limiting cables; Axle location with 8 reaction rods; Mounted on spring units which pivot on a central trunnion located by 8 torque rods.

Max. design load: 26000 kg

### Options:

- DAF 8 bag air suspension (26000 kg)

## WHEELS AND TYRES

22.5" (10 stud 335 PCD) Alcoa aluminium satin disc wheels with 295 / 80 R 22.5 tubeless radial tyres at front and dual 11 R22.5 tyres at rear.

### Options:

- Alcoa polished wheels - Steel disc wheels - silver
- Wheel protection rings

## STEERING

Type: Hydraulic power steering with adjustable steering column for rake and height.

## BRAKE SYSTEM

Dual circuit air operated drum brakes on rear axles with automatic slack adjusters; Front axle air operated disc brakes with wear indicator on instrument panel.

Brake Dimensions: 430 x 45 mm  
420 x 200 mm (Rear axle HR 1355T)

EBS (Electronic Braking System incorporating ABS); Emergency/parking brake with spring brake actuators on rear axles; MX Engine Brake and exhaust brake (retardation power 320kW at 2100rpm); ASR (Acceleration Slip Control).

### Options:

- ZF interarder only with AS Tronic (retardation power 420kW)

## ELECTRICAL EQUIPMENT

Voltage: 24 V

Alternator: 80 A

Batteries: 2 x 175 Ah

Starter Motor: 24 V

Rear light units Incorporating direction indicator light, stop light, reversing light, side marker light and reflector; Main switch with manual control located near the battery box; Reverse warning alarm.

## TRAILER EQUIPMENT

Trailer brake connectors: 2-line to rear of chassis

Trailer light connectors: 24V

### Options:

- No trailer connections

## CAB EXTERIOR

F230 tilt Day Cab with 4 coil spring suspension and hydraulic tilting device; Tilting angle 57.5°; Fixed, illuminated cab steps; Manually controlled roof hatch; Heated and electrically adjustable main and wide angle mirrors; Steel front bumper with foot hold; Combi lights, incorporating driving and fog lights in lower bumper; External sun visor; Corner air deflectors; Side collars; Air horns; Rear window.

### Options:

- Sleeper cab - Space cab
- Side window - Air horns (Dual Set)
- Adjustable roof spoiler - Remote hatch control (Space cab only)

## COLOURS

Cab colour: M8870 Ice White

Chassis colour: Black

Mirror cover and bumper colour: Cab colour

### Options:

- Various non-standard and metallic cab and chassis colours, see colour guide or dealer net.

## CAB INTERIOR

High quality trim and upholstery in natural camel-grey colour; Cab floor cover includes easy-clean top layer in camel-grey; Cockpit style dashboard, including DIP (driver information panel) and Adblue indicator; Adjustable luxury air suspended driver seat and fixed co-driver seat with head restraint; Various storage facilities including two cup holders, containers behind seat and overhead compartments; spoke, soft grip steering wheel with integrated control switches; Electric window openers (driver and passenger); Cruise control; Personal road speed limiter; Wood structure dashboard finish; Integrated 3-point seat belt; Air conditioning; Antennas: 1 x GSM; Radio/CD/MP3 player with 2 speakers; Remote control door lock.

### Options:

- Hands free telephone kit - Passenger luxury air seat
- 3rd seat (day cab only) - Driver's seat arm rest (only with AS Tronic)
- Leather finish steering wheel - Wood structure dashboard finish
- Automatic temperature control - Lane departure warning signal
- Additional upper bunk (only with space cab) - FMS connector prepared (Fleet Management System)
- Refrigerator (not available with day cab or rear window) - Bunk with sleeper cab (height depending on refrigerator and storage boxes)
- SRS drivers air bag with seat belt pretensioner on driver and passenger seats

## POWER TAKE OFF (PTO)

Engine speed control connector - PTO prepared

### Options:

- Various types of PTOs / position combinations – refer DTA

## LEGAL ASPECTS

- Exhaust emission Euro 4

- ECE R29 cab certification

- ADR 83 noise certification

- Front underrun protection certification (152N front axle only)

## APPLICATION CONDITIONS

Raised air intake on cab roof with cyclonic pre-filter behind the cab; Standard tool kit; Fuel water separator.

## MAX. SPEED

All vehicles are speed limited to 100km/h.

Depending on the vehicle configuration a specific option may not be possible. All weights and measurements should be regarded as approximate only. In the interests of product improvements DAF Trucks Australia reserve the right to change these specifications without prior notice. For further information please contact DAF Trucks Australia.